



# Lifting Points - for welding - Load Ring - VRBS -

Complies with the machinery directives 2006/42/EG

**4 SAFETY FACTOR 4:1**  
LOADABLE IN ANY DIRECTION

**-20° C**



MO  
075104

CE

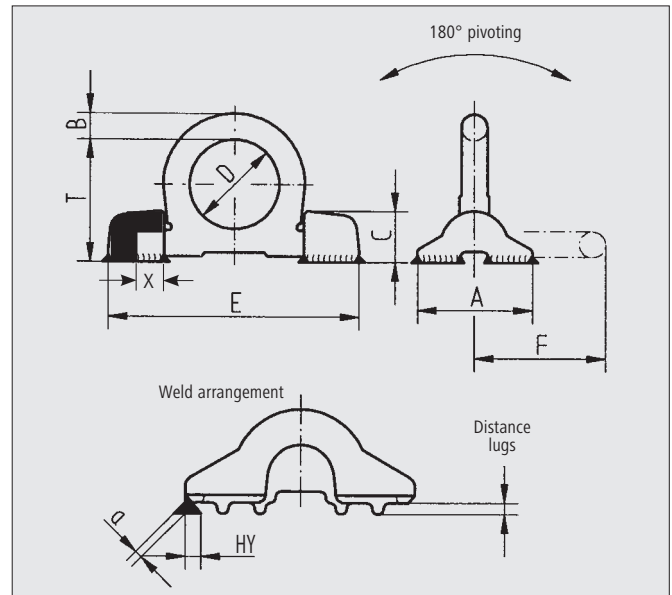

Type	WLL (t)	A	B	C	D	E	F	O	Q	X	T	Weld HY + Δ a	Weight (kg)	Ref.-No.
VRBS 4	4	62	14	28	48	135	71	17	77	14	65	HY 4 + 3	0.8	79 92 488
VRBS 6.7	6.7	88	20	39	60	170	92	23	101	15	84	HY 5.5 + 3	2.1	79 92 489
VRBS 10	10	100	22	46	65	195	100	28	106	22	95	HY 6 + 4	2.8	79 92 490
VRBS 16	16	130	30	57	90	263	134	36	147	28	127	HY 8.5 + 4	6.6	79 92 491
VRBS 31.5	31.5	160	42	78	130	375	195	47	220	37	178	HY 18 + 4	19.0	60267
VRBS 50	50	240	70	120	230	620	340	65	380	—	313	HY 25 + 8	54.1	56 834

- Distribution of the load force due to the 2 point fixing, hence an optimised force introduction to the work piece.
- Forged, suspension ring acc. to EN 1677-1, electromagnetic crack detected, pink powder coated. Suspension ring can also be ordered single. For instance VRL 4. This lifting point fulfils the requirements of the appropriate safety authorities (German Employers Insurance Association). Stamped.
- Lays flat when not in use.
- Low profile.
- Rounded well shaped design.
- High dynamic and static strength.
- The welding blocks are forged out of the ideal weldable steel S355J2+N (St 52-3N) and the nominal WLL is embossed.

- Patented distance lugs assist in achieving the correct root weld (approx. 3 mm).
- The weld arrangement (continuous HY weld) fulfils the requirements of DIN 18800 i.e. the closed weld avoids corrosion and is thus suitable for outdoor use.

**Attention:** Refer to the RUD user welding instructions!

