



Lifting Points - for bolting -

Maximum transport weight „G“ in „tonnes“ with different lifting methods

4 SAFETY FACTOR 4:1
LOADABLE IN ANY DIRECTION

RUD®



Complies with the machinery directives 2006/42/EG

Thread sizes M 6- M 150 Imperial (UNC....) and special lengths on request		PP-S (Vario) PowerPoint-Star		PP-B (Vario) PowerPoint-B		PP-VIP (Vario) PowerPoint-VIP		VLBG – Load Ring (Vario)																														
Number of legs	Load direction	Thread size	Typ		PP-S 0.63 t		PP-S 1.5 t		PP-S 2.5 t		PP-S 4 t		PP-S 5 t		PP-S 8 t		VLBG																					
			Typ	PP-S 0.63 t	PP-S 1.5 t	PP-S 2.5 t	PP-S 4 t	PP-S 5 t	PP-S 8 t	VLBG 0.3 t	VLBG 0.63 t	VLBG 1 t	VLBG 1.5 t	VLBG 2.5 t	VLBG 4 t	VLBG 4 t	VLBG 5 t	VLBG 7 t Sond.	VLBG 8 t	VLBG 10 t	VLBG 15 t	VLBG 20 t	VLBG 20 t	VLBG 20 t	VLBG 20 t													
	1 0°	M 12	0.6	1.5	2.5	4	6.7	10	0.3	0.6	1	1.5	2.5	4	4	5	7	8	10	15	20	1	2	0.3	0.6	1	1.5	2.5	4	4	5	7	8	10	15	20	1	2
	2 0°	M 12	1.2	3	5	8	13.4	20	0.6	1.2	2	3	5	8	8	10	14	16	20	30	40	2	4	0.6	1.2	2	3	5	8	8	10	14	16	20	30	40	2	4
	1 90°	M 12	0.6	1.5	2.5	4	5	8	0.3	0.6	1	1.5	2.5	4	4	5	7	8	10	15	20	1	2	0.3	0.6	1	1.5	2.5	4	4	5	7	8	10	15	20	1	2
	2 90°	M 12	1.2	3	5	8	10	16	0.6	1.2	2	3	5	8	8	10	14	16	20	30	40	2	4	0.6	1.2	2	3	5	8	8	10	14	16	20	30	40	2	4
	2 0-45°	M 12	0.8	2.1	3.5	5.6	7	11.2	0.4	0.8	1.4	2.1	3.5	5.6	5.6	7	9.8	11.2	14	21	28	1.4	2.8	0.4	0.8	1.4	2.1	3.5	5.6	5.6	7	9.8	11.2	14	21	28	1.4	2.8
	2 45-60°	M 12	0.6	1.5	2.5	4	5	8	0.3	0.6	1	1.5	2.5	4	4	5	7	8	10	15	20	1	2	0.3	0.6	1	1.5	2.5	4	4	5	7	8	10	15	20	1	2
	2 unsymmetrical	M 12	0.6	1.5	2.5	4	5	8	0.3	0.6	1	1.5	2.5	4	4	5	7	8	10	15	20	1	2	0.3	0.6	1	1.5	2.5	4	4	5	7	8	10	15	20	1	2
	3+4 0-45°	M 12	1.3	3.1	5.2	8.4	10.5	16.8	0.6	1.3	2.1	3.1	5.2	8.4	8.4	10.5	14.7	16.8	21	31.5	42	2.1	4.2	0.6	1.3	2.1	3.1	5.2	8.4	8.4	10.5	14.7	16.8	21	31.5	42	2.1	4.2
	3+4 45-60°	M 12	0.9	2.2	3.7	6	7.5	12	0.4	0.9	1.5	2.2	3.7	6	6	7.5	10.5	12	15	22.5	30	1.5	3	0.4	0.9	1.5	2.2	3.7	6	6	7.5	10.5	12	15	22.5	30	1.5	3
	3+4 unsymmetrical	M 12	0.6	1.5	2.5	4	5	8	0.3	0.6	1	1.5	2.5	4	4	5	7	8	10	15	20	1	2	0.3	0.6	1	1.5	2.5	4	4	5	7	8	10	15	20	1	2
		Thread size	M 12	M 16	M 20	M 24	M 30	M 36	M 8	M 10	M 12	M 16	M 20	M 24	M 27	M 30	M 36	M 36	M 42	M 42	M 48	M 16	M 20	M 8	M 10	M 12	M 16	M 20	M 24	M 27	M 30	M 36	M 36	M 42	M 42	M 48	M 16	M 20

RUD Lifting Points

- All parts are either 100 % crack detected or proof loaded accord. to EN 1677.
- All original bolts from RUD are 100 % crack detected.
- Loadable in any direction. Safety factor 4 : 1.
- Types VRS, VRM and VLBG have to be adjusted to the load direction.
- RUD patented features such as clamping spring (VLBS) for noise reduction and distance lugs for a perfect root pass weld increase the ease of use.

- Low installation height, high dynamic and static strength.
- RUD Lifting Points are in accordance with DIN EN 818 and 1677 with a dynamic loading of more than 20,000 load cycles. The BG* recommends: At high dynamic applications with high load cycles (permanent operation), the WLL must be reduced or ask the manufacturer.

* BG-German Employers Liability Insurance.



Lifting Points - for bolting -

Maximum transport weight „G“ in „tonnes“
with different lifting methods

4 SAFETY FACTOR 4:1
LOADABLE IN ANY DIRECTION



Complies with the machinery directives 2006/42/EG

**VWBG-V
Load Ring
(Vario)**

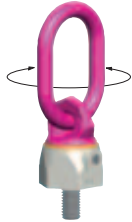

**VWBG
Load Ring**

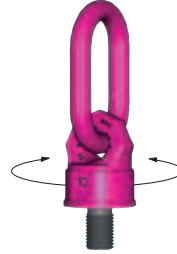

VWBG-V Load Ring (Vario)											VWBG Load Ring																					
WVWG-V 0.3 t	WVWG-V 0.45 t	WVWG-V 0.6 t	WVWG-V 1.0 t	WVWG-V 1.3 t	WVWG-V 1.8 t	WVWG-V 2 t	WVWG-V 2 t	WVWG-V 3.5 t	WVWG-V 3.5 t	WVWG-V 5 t	WVWG 6 (7.5)	WVWG 8 (10)	WVWG 8 (10)	WVWG 12 (13)	WVWG 12 (13)	WVWG 12 (15)	WVWG 13 (16)	WVWG 13 (16)	WVWG 14 (20)	WVWG 16 (22)	WVWG 16 (22)	WVWG 16 (25)	WVWG 16 (25)	WVWG 16 (25)	WVWG 16 (25)	WVWG 31.5 (40)	WVWG 31.5 (40)	WVWG 35 (48)	WVWG 35 (48)	WVWG 40 (50)	WVWG 40 (50)	
M 8	M 10	M 12	M 14	M 16	M 18	M 20	M 22	M 24	M 27	M 30	M 33	M 36	M 36-39	M 42	M 42-45	M 45	M 48	M 48-52	M 52	M 56	M 56-62	M 64	M 64-76	M 64-76	M 64-76	M 72	M 72-76	M 80	M 80-85	M 90	M 90-150	
0.6	0.9	1.2	2.0	2.6	3.6	4	4	7	7	10	15	15	15	17	17	18	18	18	25	28	28	28	28	28	28	28	50	50	50	50	50	50
1.2	1.8	2.4	4.0	5.2	7.2	8	8	14	14	20	30	30	30	34	34	36	36	36	50	56	56	56	56	56	56	56	100	100	100	100	100	100
0.3 (0.4)	0.45 (0.6)	0.6 (0.75)	1.0 (1.25)	1.3 (1.5)	1.8 (2.0)	2 (2.5)	2 (2.5)	3.5 (4)	3.5 (4)	5 (6)	6 (7.5)	8 (10)	8 (10)	12 (13)	12 (13)	12 (15)	13 (16)	13 (16)	14 (20)	16 (22)	16 (22)	16 (25)	16 (25)	16 (25)	16 (25)	31.5 (40)	31.5 (40)	35 (48)	35 (48)	40 (50)	40 (50)	
0.6 (0.8)	0.9 (1.2)	1.2 (1.5)	2.0 (2.5)	2.6 (3)	3.6 (4.0)	4 (5)	4 (5)	7 (8)	7 (8)	10 (12)	12 (15)	16 (20)	16 (20)	24 (26)	24 (26)	24 (30)	26 (32)	26 (32)	28 (40)	32 (44)	32 (44)	32 (50)	32 (50)	32 (50)	32 (50)	63 (80)	63 (80)	70 (96)	70 (96)	80 (100)	80 (100)	
0.42 (0.56)	0.63 (0.84)	0.84 (1.05)	1.4 (1.75)	1.81 (2.1)	2.52 (2.8)	2.8 (3.5)	2.8 (3.5)	4.9 (5.6)	4.9 (5.6)	7 (8.4)	8.4 (10.5)	11.2 (14)	11.2 (14)	16.8 (18.2)	16.8 (18.2)	16.8 (21)	18.2 (22.4)	18.2 (22.4)	19.6 (28)	22.4 (30.8)	22.4 (30.8)	22.4 (35)	22.4 (35)	22.4 (35)	22.4 (35)	44.1 (56)	44.1 (56)	49 (67.2)	49 (67.2)	56 (70)	56 (70)	
0.3 (0.4)	0.45 (0.6)	0.6 (0.75)	1.0 (1.25)	1.3 (1.5)	1.8 (2)	2 (2.5)	2 (2.5)	3.5 (4)	3.5 (4)	5 (6)	6 (7.5)	8 (10)	8 (10)	12 (13)	12 (13)	12 (15)	13 (16)	13 (16)	14 (20)	16 (22)	16 (22)	16 (25)	16 (25)	16 (25)	16 (25)	31.5 (40)	31.5 (40)	35 (48)	35 (48)	40 (50)	40 (50)	
0.3 (0.4)	0.45 (0.6)	0.6 (0.75)	1.0 (1.25)	1.3 (1.5)	1.8 (2)	2 (2.5)	2 (2.5)	3.5 (4)	3.5 (4)	5 (6)	6 (7.5)	8 (10)	8 (10)	12 (13)	12 (13)	12 (15)	13 (16)	13 (16)	14 (20)	16 (22)	16 (22)	16 (25)	16 (25)	16 (25)	16 (25)	31.5 (40)	31.5 (40)	35 (48)	35 (48)	40 (50)	40 (50)	
0.63 (0.84)	0.94 (1.26)	1.26 (1.57)	2.1 (2.62)	2.73 (3.15)	3.78 (4.2)	4.2 (5.25)	4.2 (5.25)	7.35 (8.4)	7.35 (8.4)	10.5 (12.6)	12.6 (15.7)	16.8 (21)	16.8 (21)	25.2 (27.3)	25.2 (27.3)	25.2 (31.5)	27.3 (33.6)	27.3 (33.6)	29.4 (42)	33.6 (46.2)	33.6 (46.2)	33.6 (52.5)	33.6 (52.5)	33.6 (52.5)	33.6 (52.5)	66.15 (84)	66.15 (84)	73.5 (100)	73.5 (100)	84 (105)	84 (105)	
0.45 (0.6)	0.67 (0.9)	0.9 (1.12)	1.5 (1.87)	1.95 (2.25)	2.7 (3)	3 (3.75)	3 (3.75)	5.25 (6)	5.25 (6)	7.5 (9)	9 (11.2)	12 (15)	12 (15)	18 (19.5)	18 (19.5)	18 (22.5)	19.5 (24)	19.5 (24)	21 (30)	24 (33)	24 (33)	24 (37.5)	24 (37.5)	24 (37.5)	24 (37.5)	47.25 (60)	47.25 (60)	52.5 (72)	52.5 (72)	60 (75)	60 (75)	
0.3 (0.4)	0.45 (0.6)	0.6 (0.75)	1.0 (1.25)	1.3 (1.5)	1.8 (2)	2 (2.5)	2 (2.5)	3.5 (4)	3.5 (4)	5 (6)	6 (7.5)	8 (10)	8 (10)	12 (13)	12 (13)	12 (15)	13 (16)	13 (16)	14 (20)	16 (22)	16 (22)	16 (25)	16 (25)	16 (25)	16 (25)	31.5 (40)	31.5 (40)	35 (48)	35 (48)	40 (50)	40 (50)	
M 8	M 10	M 12	M 14	M 16	M 18	M 20	M 22	M 24	M 27	M 30	M 33	M 36	M 36-39	M 42	M 42-45	M 45	M 48	M 48-52	M 52	M 56	M 56-60	M 64	M 64-76	M 64-76	M 64-76	M 72	M 72-76	M 80	M 80-85	M 90	M 90-150	

We have the right tools for you. Call us! Phone no. or e-mail:

+49 7361-504-1170 or slings@rud.com

The perfect service for the CAD department.

We provide you with geometry datas for your design.

For the calculation of the right lifting point. Especially useful for the designer is the 3D-presentation of the lifting points.

...click www.rud.com

Click on [lifting means](#) → [lifting points](#)



Always
"up to
date"!

Subject to technical alternatives!





Lifting Points - for bolting - Load Ring bolted - VWBG-V -

– 360° swivelling/230° pivoting –



Complies with the machinery directives 2006/42/EG

4 SAFETY FACTOR 4:1
LOADABLE IN ANY DIRECTION

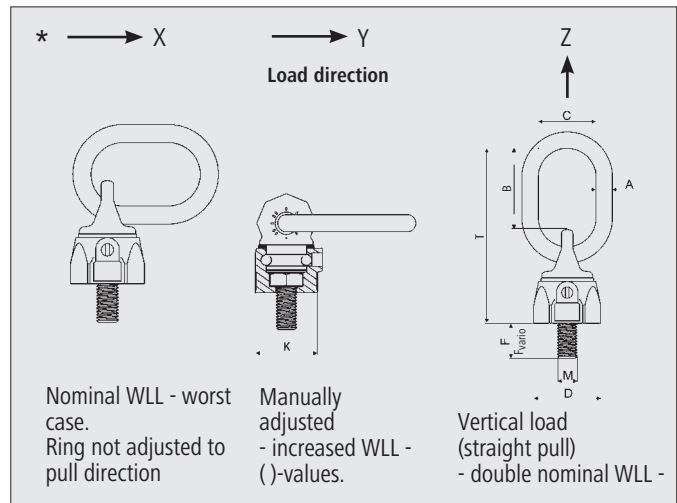
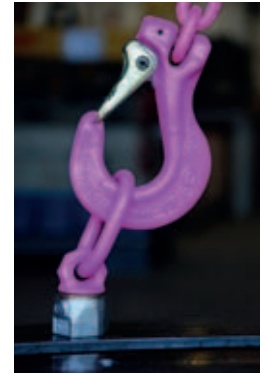
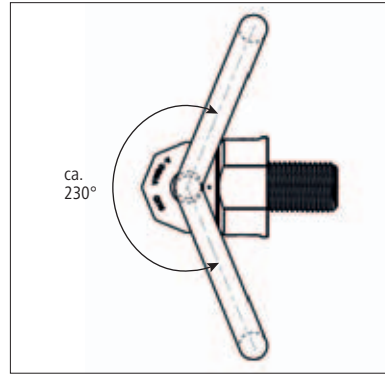
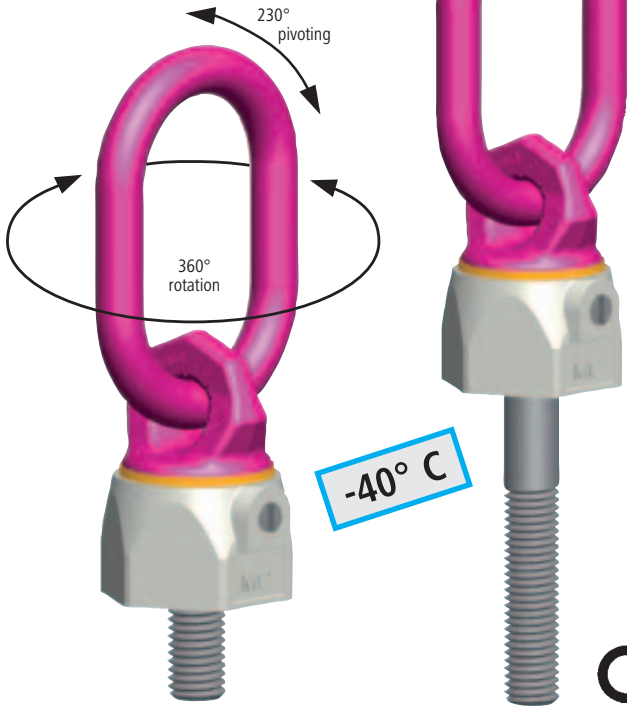

Type	WLL [t]	A [mm]	B [mm]	C [mm]	D [mm]	F _{stand.} [mm]	F _{vario} [mm]	K [mm]	M [mm]	T [mm]	X [mm]	Ref.-No. Stand.	Ref.-No. Vario with washer and nut
VWBG-V 0.3 M8	0.3(0.4)	8	31	29	30	13	8-102	28	8	76	18	7103720	8600330
VWBG-V 0.45 M10	0.45(0.6)	8	31	29	36	17	10-122	30	10	78	19	7103715	8600331
VWBG-V 0.6 M12	0.6(0.7)	10	49	35	42	21	12-140	36	12	107	19	7100180	8600332
VWBG-V 1.0 M14	1.0(1.25)	13	46	38	48	21	14-65	41	14	113	–	–	8600337
VWBG-V 1.3 M16	1.3(1.5)	13	46	38	48	25	16-180	41	16	113	28	7100430	8600333
VWBG-V 1.8 M18	1.8(2.0)	13	54	35	62	27	18-83	55	18	137	–	–	8600338
VWBG-V 2.0 M20	2.0(2.5)	13	54	35	62	33	20-223	55	20	137	30	7100800	8600334
VWBG-V 2.0 M22	2.0(2.5)	13	54	35	62	33	22-94	55	22	137	–	–	8600334
VWBG-V 3.5 M24	3.5(4.0)	18	66	40	81	40	24-255	70	24	173	25	7100640	8600335
VWBG-V 3.5 M27	3.5(4.0)	18	66	40	81	40	27-92	70	27	173	–	–	8600335
VWBG-V 5.0 M30	5.0(6.0)	22	90	50	99	50	30-330	85	30	221	32	7100650	8600336

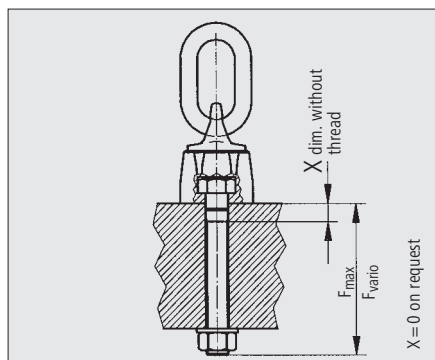

Example to investigate the required thread length F_{vario}:
F_{vario}: Plate thickness 50 mm, through hole for M 20 bolt, height of nut 22 mm, thickness of the washer 3 mm, plus bolt projection 5 mm = 80 mm.
Order length: VWBG-V-2.0 M 20 x 80.

***Caution:** During lifting, the ring of the lifting point can engage in any position. The embossed WLL is for the worst case scenario (see image X). If the ring is manually adjusted to the horizontal position, higher WLL values in brackets () can be chosen (see image Y). In case of straight pull (see image Z: vertical load direction) Maximum WLL can be chosen. The nominal WLL can be increased acc. the chart from page 7!

Swivelling lifting point:

- Loadable in any direction. Safety factor 4 : 1.
- Turnable under load in vertical direction.
- Not suitable for permanent swivelling under full load, especially in 90° direction.
- Simple installation, just a thread hole is required.
- Variable lengths (Vario) available.
- Can also be used for through holes.
- Bolts 100 % magnetic crack detected! Surface protection CORRUD-DT (20 times better than zinc plating).
- High tensile, approved suspension ring acc. EN 1677-4.
- Surface: Ring pink powder coating, housing zinc plated.
- Type Vario with washer and 100 % crack detected nut.
- VWBG-V and VWBG are also available with Imperial thread.
- Turning without jerk due to additional bush bearing washer.
- Wear marks in the main load directions 45°, 60° and 90°.



Lifting Points - for bolting - Load Ring bolted - VWBG -

- 360° swivelling/230° pivoting – with a ball bearing

Complies with the machinery directives 2006/42/EG

4 SAFETY FACTOR 4:1
LOADABLE IN ANY DIRECTION

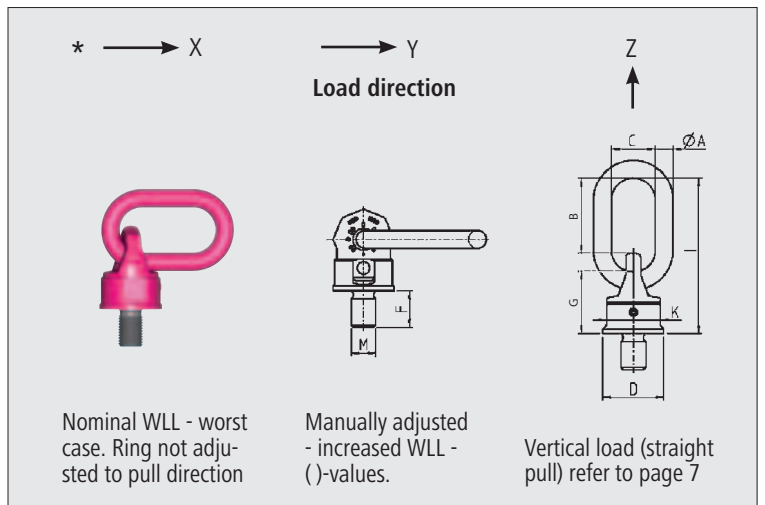
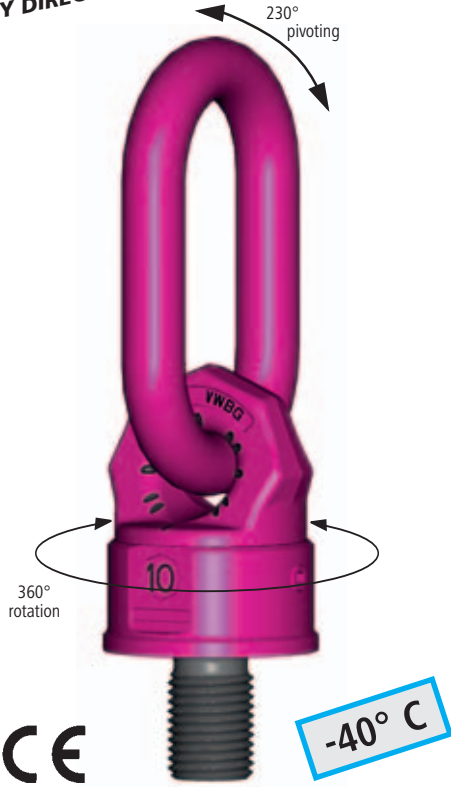

Type	WLL [t]	A [mm]	B [mm]	C [mm]	D [mm]	F _{stand.} [mm]	F _{vario} [mm]	G [mm]	K [mm]	M [mm]	T [mm]	Ref.-No. Stand.	Ref.-No. Vario with washer and nut
VWBG 6(7.5) M33	6(7.5)	22	86	50	90	—	33-300	94	80	33	208	—	8600150
VWBG 8(10) M36-39	8(10)	22	86	50	90	54	36-300	94	80	36-39	208	7999059	8600451
VWBG 12(13) M42-45	12(13)	26	111	65	98	63	42-300	96	85	42-45	235	7999044	8600452
VWBG 12(15) M45	12(15)	26	111	65	98	67	—	96	85	45	235	7900455	—
VWBG 13(16) M48-52	13(16)	26	111	65	98	68	48-300	96	85	48-52	235	7999045	8600453
VWBG 14(20) M52	14(20)	32	119	70	120	78	52-300	120	95	52	274	7901081	8600158
VWBG 16(22) M56-62	16(22)	32	119	70	120	84	56-300	120	95	56-62	274	7999004	8600454
VWBG 16(25) M64-76	16(25)	32	119	70	120	94	64-300	120	95	64-76	274	7999043	8600455
VWBG 31.5(40) M72-76	31.5(40)	46	130	90	170	108	72-300	159	145	72-76	338	7900097	8600456
VWBG 35(48) M80-85	35(48)	46	130	90	170	120	80-300	159	145	80-85	338	7900100	8600457
VWBG 40(50) M90-150	40(50)	46	130	90	170	135	90-300	159	145	90-150	338	7995545	8600157
VWBG 40(50) M90-150	40(50)	46	170	110	170	135	90-300	159	145	90-150	378	7903408	8600458

Definieren Sie bitte Ihre gewünschten Abmessungen F und M

***Caution:** During lifting, the ring of the lifting point can engage in any position. The embossed WLL is for the worst case scenario (see image X). If the ring is manually adjusted to the horizontal position, higher WLL values in brackets () can be chosen (see image Y). In case of straight pull (see image Z: vertical load direction) Maximum WLL can be chosen. The nominal WLL can be increased acc. the chart from page 7!

For heavy loads which have to be turned and swivelled.

- **With ball bearings.** Swivels under full load.
- Not suitable for permanent swivelling under full load, especially in 90° direction.
- Loadable in any direction. Safety factor 4 : 1.
- Suspension ring manufactured acc. EN 1677-4 grade 80 (100 % proof loaded).
- S = max. allowed gap, see hints for Installation page 39.
- VWBG: Wear marks in the main load directions 45°, 60° and 90°.

Safety notice:

Please provide plain bolting surface. The countersunk for the thread should be: thread diameter plus 4 mm (0,15 inch). The base material of the workpiece must be capable to withstand the occurring lifting forces. Minimum required material = S235JR/St 37 (1.0037).

